

WARRANTY

Dear Customer,

You are now the privileged owner of Transducer a product that ranks the first of its kind in the world.

Company provides 12 months warranty from the original date of purchase against defective material and workmanship.

In the unlikely event of failure of this Transducer within the warranty period, Company will repair the Transducer free of charge. Please hand over the Transducer to the dealer / Stockiest from whom you have purchased along with this card and relevant cash memo / Invoice. This warranty entitles you to bring the Transducer at your cost to the nearest stockiest / dealer and collect it after repairs.

NO TRANSPORTATION CHARGES WILL BE REIMBURSED

The warranty is not valid in following cases:

- 1) Warranty card duly signed / stamped and original cash memo / invoice are not sent along with the Transducer .
- 2) Complete warranty card is not presented to authorised person at the time of repairs.
- 3) Transducer not used as per the instruction in the user manual.
- 4) Defect caused by misuse, negligence, accidents, tampering and acts of god.
- 5) Improper repairing by any person not authorised by the company.
- 6) Any sort of modification, alteration is made in electrical circuitry.
- 7) Seal provided inside is broken.

In case of dispute to the validity of warranty, the decision of Company's service center will be final.

If you bought this Transducer directly from the company, and if you notice transit Damage, then you must obtain the insurance surveyors report and forward it to Company.

Thank you.

(To be filled by authorized dealer)

Model No. : _____
Serial Number : _____
Date of Purchase : _____
Cash Memo / Invoice No. : _____
Dealer's Signature : _____
Dealer's Stamp : _____

Scope of Supply:

- 1) Transducer
- 2) Instruction manual
- 3) Test Certificate
- 4) Warranty Card
- 5) RS-232 Interface Cable*
- 6) Software*

* Only with Theta 40 Transducer

Operating Instructions Isolating amplifier Transducer *THETA 60I*



2-60-006-00-00547

Rev. A_10/2014



Sifam Tinsley Instrumentation
3105, Creekside Village Drive,
Suite No 801, Kennesaw,
Georgia 30144
Contact Number: +1.404.736.4903
Web: www.sifamtinsley.com

Sifam Tinsley Instrumentation Ltd.
Central Buildings, Woodland Close,
Old Woods Trading Estate,
Torquay, Devon, England, TQ27BB
Website: www.sifamtinsley.com/uk
Contact Number: +44(O) 1803 615139
E-mail: info@tinsley.co.uk

Operating Instructions

Isolating amplifier Transducer *THETA 60I*

Contents

1. Read first and then	2
2. Scope of supply	2
3. Ordering Information	2
4. Brief description	2
5. Overview of the parts	2
6. Technical data	3
7. Exchanging front plates	4
8. Withdrawing and inserting the device	4
9. Mounting	4
10. Electrical connections	5
11. Configuration	6
12. Commissioning	7
13. Maintenance	7
14. Releasing the isolating amplifier	7
15. Dimensional drawings	7

1. Read first and then



The proper and safe operation of the device assumes that the Operating Instructions are **read** and the **safety** warnings given in the various sections

9. Mounting
10. Electrical Connections
11. Commissioning

are observed.

The device should only be handled by appropriately trained personnel who are familiar within and authorised to work in electrical installations.

2. Scope of supply (Fig. 1)

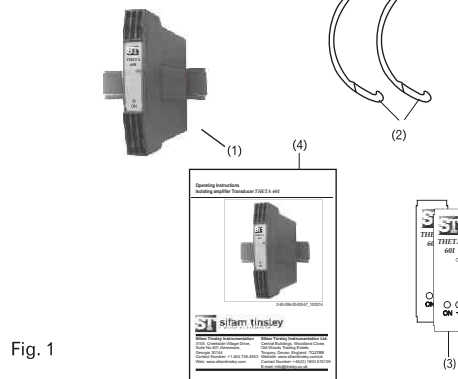

Fig. 1

Isolating amplifier (1)

- 2 **Withdrawing handle (2)** (for withdrawing the device from its housing)
- 2 **Front plates (3)** (for notes)
- 1. **Operating Instructions (4)**

3. Ordering Information

DESCRIPTION	MARKING
1. Mechanical design Housing S17	808 - 1
2. Number of channels 2 channels	2
3. Version / Power supply $\rightarrow \odot$ Standard, 24 ... 60 V DC/AC Standard, 85 ... 230 V DC/AC	1 2
4. Function 2 inputs, 2 electrically insulated outputs 1 input, 2 electrically insulated outputs	2 3
5. Input signal, input 1 $\rightarrow \ominus$ input [V] <input type="text"/> acc. to type label input [mA] <input type="text"/> acc. to type label	9 Z
6. Output signal, output 1 $\rightarrow \oplus$ output [V] <input type="text"/> acc. to type label output [mA] <input type="text"/> acc. to type label	9 Z
7. Input signal, input 2 $\rightarrow \ominus$ Without input 2 input [V] <input type="text"/> acc. to type label input [mA] <input type="text"/> acc. to type label	0 9 Z
8. Output signal, output 2 $\rightarrow \oplus$ output [V] <input type="text"/> acc. to type label output [mA] <input type="text"/> acc. to type label	9 Z

4. Brief description

The purpose of the isolating amplifier *THETA 60I* Transducer is to electrically insulate input and output signals, respectively to amplify and/or change the signal level or type (current or voltage) of the input signals.

5. Overview of the parts

Figure 2 shows those parts of the device of consequence for mounting, electrical connections and other operations described in the Operating instructions.

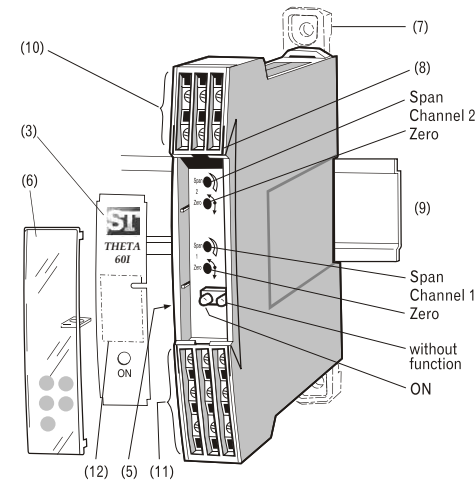

- (3) Front plate
 - (5) Type label
 - (6) Transparent cover
 - (7) Fixing bracket
 - (8) Opening for withdrawing clip (for opening the housing)
 - (9) Top-hat rail 35 x 15 mm or 35 x 7.5 mm (EN 50 022)
 - (10) Terminals
 - (11) Terminals
 - (12) Space for notes
- ON Green LED for indicating device standing by

6. Technical Data

Measuring Input $\rightarrow \ominus$

DC Current : Limit values
0...0.1 to 0...40 mA
also live-zero,
start value >0 to ≤50% final value
-0.1...0...+0.1 to
-20...0...+20mA
also bipolar asymmetrical
max. span : ≤40 mA
 $R_i = 15\Omega$

DC Voltage : Limit values
0...0.06 to 0...40 mA
also live-zero,
start value >0 to ≤50% final value
(-0.06...0...+0.06 to
-20...0...+20 V)
max. span : ≤40 V
 $R_i = 100K\Omega$

Overload : DC current
Continuously 2-fold
DC voltage
Continuously 2-fold

Measuring Outputs $\rightarrow \oplus$

DC Current : Standard ranges
0...20mA, 4...20mA, ±20mA
Limit values
0...1 to 0...20 mA
0.2...1 to 4...20mA
-1...0...+1 to -20...0...+20mA

Burden Voltage : 12V

External resistance : $R_{ext} \max. (K\Omega) = \frac{12V}{I_{AN} (mA)}$
 I_{AN} = output circuit full-scale value

DC Voltage : Standard ranges
0...10V, 2...10V, ±10V
Limit values
0...1 to 0...10 V
0.2...1 to 2...10V
-1...0...+1 to -10...0...+10V

Burden : $R_{ext} \min. (K\Omega) \geq \frac{U_{AN} [V]}{5mA}$
 U_{AN} = output circuit full-scale value

Current limiter at $R_{ext} \max. :$ Approx. 1.1 x I_{AN} for current output

Voltage limiter at $R_{ext} \infty :$ Approx. 13V

Residual ripple in Output current : < 0.5 % p.p.

Response time : < 50 ms

Power supply $H \rightarrow \odot$

AC/DC power pack (DC and 45...400 Hz)

Table 1 : Nominal voltages and tolerances

Nominal voltage U_N	Tolerance
24... 60 V DC / AC	DC - 15... + 33 %
85... 230 V ¹ DC / AC	AC ±15%

¹ For power supplies > 125 V, the auxiliary circuit should include an external fuse with a rating ≤ 20 A D.C.

Power input : ≤ 1.2 W resp. ≤ 3VA

Accuracy data (acc. to DIN/IEC 770)

Basic accuracy : Limit error ≤ ± 0.2%
Including linearity and reproducibility errors

Installation data

Terminals :	DIN/VDE 0609 Screw terminals with wire guards, for light PVC wiring and max. 2 x 0.75 mm ² or 1 x 2.5 mm ²
Permissible Vibrations :	2 g acc. to EN 60 068-2-6
Shocks :	3 x 50 g 2 shocks each in 6 directions Acc. to EN 60 068-2-27

Electrical insulation : All circuits (measuring inputs/ measuring outputs / power supply) are electrically insulated

Regulation

Hosing protection
(acc. to IEC 529
resp. EN 60529) : IP 40
Terminals : IP 20

Electrical standards: Acc. to IEC 1010 resp. EN 61 010

Test voltage : Power supply versus :
- all 3.7 kV, 50 Hz, 1 min.

Measuring inputs versus :
- measuring outputs 2.3 kV,
50 Hz, 1 min.

Measuring inputs 1 versus :
- measuring input 2
2.3 kV, 50 Hz, 1 min.

Measuring output 1 versus :
- measuring output 2
2.3 kV, 50 Hz, 1 min.

Environmental conditions

Climatic rating : Climate class 3Z acc. to
VDI/VDE 3540

Commissioning
Temperature : -10 to +55°C
Operating
Temperature : -25 to +55°C
Storage Temp. : -40 to +70°C
Annual mean
Relative humidity : ≤ 75 %

7. Exchanging front plates

Apply gentle pressure to the transparent cover as shown in Fig. 3 until pops out on the opposite side. The label in the cover can be replaced and used for notes. After replacing the label in the transparent cover, the transparent cover can be snapped into the front of the device again. This is done by inserting it behind the edge at the bottom and pressing it gently down and to the rear with the finger until it snaps into place (right side of Fig. 3)

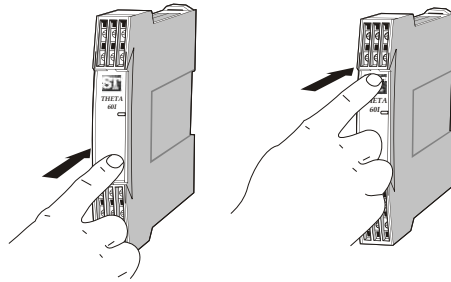

Fig. 3 Left : Removing the transparent cover
Right : Inserting the transparent cover.

8. Withdrawing and inserting the device

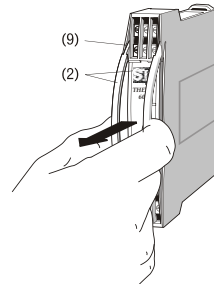

Fig. 4

Insert the withdrawing handles (2) into the openings (9) until they snap into place. Withdraw the front part together with the main PCB out of the housing. To reassemble the unit, insert the front part together with the main PCB the housing until the swallow-tailed sections engage in each other.

9. Mounting

The **Ziegler** Transducer TV 808 can be mounted either on a top-hat rail or directly onto a wall or mounting plate.



Make sure that the ambient temperature stays within the permissible limits :
-25 and +55°C

9.1 Top-hat rail mounting

Simply clip the device onto the top-hat rail (EN 50 022) (see Fig. 5).

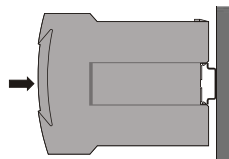

Fig. 5. Mounting on top-hat rail 35 x 15 or 35 x 7.5 mm.

9.2 Wall mounting

While pressing the latch (4) in the base of the device (Fig. 6, left) pull out the isolating amplifier securing brackets(1). To return the brackets to their original positions, the latch (5) in the base of the device has to be depressed before applying pressure to the securing brackets (1) (see Fig. 6, right)

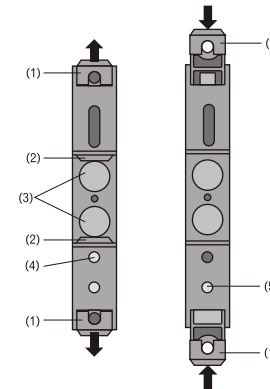

Fig. 6. Rear of device

- (1) Screw hole brackets
- (2) Top-hat rail clip
- (3) Rubber buffers
- (4) Latch for pulling the screw hole brackets out
- (5) Latch for pushing the screw hole bracket in

Drill 2 holes in the wall or panel as shown in the drilling pattern (Fig. 7). Now secure the power pack to the wall or panel using two 4 mm diameter screws.

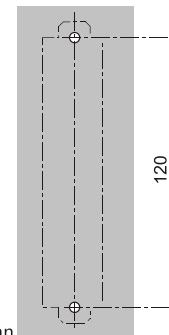

Fig. 7. Drilling plan

10. Electrical connections

The electrical connections are made to screw terminals which are easily accessible from the front of the power pack and can accommodate wire gauges up to max. 2.5 mm².



Make sure that the cables are not live when making the connections !

The 230 V power supply is potentially dangerous !



Note that, ...

... the data required to perform the electrical insulation task agree with the data on the nameplate of the **THETA 60I** Transducer (⊖ input E, ⊕ output A and ⊖ power supply H !)

... the total loop resistance connected to the output (receiver plus leads) **does not** exceed the maximum permissible value R_{ext} max. See "**Measuring Output**" in sec. "6. Technical data" for the maximum values of R_{ext} !

... the input and output cables should be twisted pairs and run as far as possible away from heavy current cables !

In all other respects, observe all local regulations when selecting the type of electrical cable and installing them !

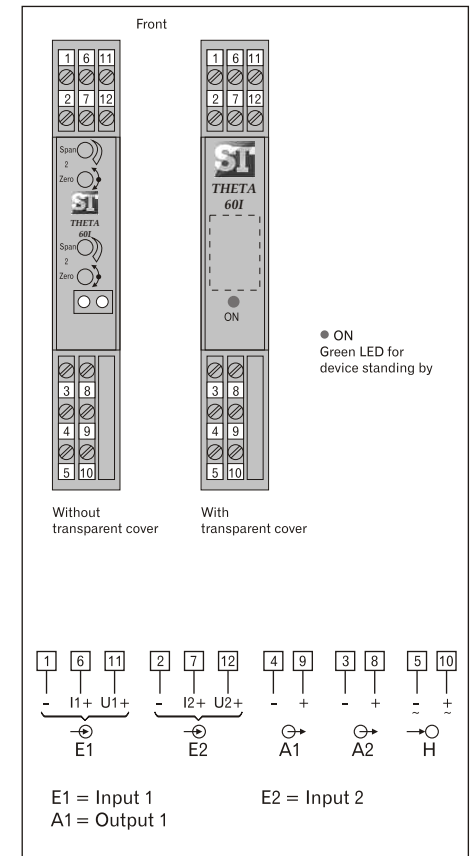

Notes

10.1 Connecting the measuring input leads

Measurement/Application	Input 1	Input 2
DC Current measurement	1 (-), 6 (I1+)	2 (-), 7 (I2+)
DC Voltage measurement	1 (-), 11 (U1+)	2 (-), 12 (U2+)

10.2 Connecting the measuring output leads

Connect the measuring output leads A1 to terminals 4(-) and 9(+), the leads A2 to terminals 3(-) and 8(+).

Note : Take care that the amplifier's maximum permissible external burden R_{ext} is not exceeded (see section "6. Technical data").

10.3 Connecting the Power supply leads

Connect the power supply leads to terminals 5(=) and 10(±)

A two-pole switch must be included in the supply connection where facility for switching *THETA 60I* Transducer off is desired.

Note: An external supply fuse with a rupture capacity ≤ 20 A must be provided for DC supply voltage > 125 V.

11. Configuration

The *THETA 60I* Transducer unit has to be opened before it can be configured (see section "8. Withdrawing and inserting the device").

11.1 Standard input ranges

Soldered jumpers are provided for the coarse setting of the input ranges and the fine adjustment is accomplished using the potentiometers "Zero" and "Span".

100 must be added to the designations of the soldered jumpers in the table for channel 1 and 200 for channel 2.

(Example : Input range for input 1 and input 2 = 0...20mA. Jumpers 1,5,6 and 11 must be inserted for this range.

- The corresponding jumpers for channel 1 are B101, B105, B106 and B111.

- The corresponding jumpers for channel 2 are B201, B205, B206 and B211.

Current [mA]	Soldered jumpers		
0 ... 0.1	1,3	7, 10, 11	
0 ... 0.2	1,3	8, 11	
0 ... 0.5	1,4	9, 10, 11	
0 ... 1	1,4	7, 10, 11	
0 ... 2	1,4	8, 11	
0 ... 5	1,5	6, 7, 8, 10, 11	
0 ... 10	1,5	10, 11	
0 ... 20	1,5	6, 11	
0.2 ... 1	1,4	8, 10, 11	12, 15
1 ... 5	1,4	6, 9	12, 15
2 ... 10	1,5	6, 7, 10, 11	12, 15
4 ... 20	1,5	6, 7, 8, 11	12, 15
- 0.1 ... 0 ... + 0.1	1,3	8, 11	13, 14, 16
- 0.2 ... 0 ... + 0.2	1,3	7, 9	13, 14, 16
- 0.5 ... 0 ... + 0.5	1,4	7, 10, 11	13, 14, 16
- 1 ... 0 ... + 1	1,4	8, 11	13, 14, 16
- 2 ... 0 ... + 2	1,4	6, 9	13, 14, 16
- 5 ... 0 ... + 5	1,5	10, 11	13, 14, 16
- 10 ... 0 ... + 10	1,5	6, 11	13, 14, 16
- 20 ... 0 ... + 20	1,5	6, 7	13, 14, 16

Voltage [V]	Soldered jumpers		
0 ... 0.06		6, 9, 10, 11	
0 ... 0.1		7, 8, 10, 11	
0 ... 0.2		6, 8, 9, 11	
0 ... 0.5		6, 7, 8, 9, 10	
0 ... 1	2	6, 7, 8, 10, 11	
0 ... 2	2	7, 8, 9, 11	
0 ... 5	2	8, 10	
0 ... 10	1	10, 11	
0 ... 20	1	6, 11	
0 ... 40	1	8	
0.2 ... 1	2	9, 10, 11	12, 15
1 ... 5	2	6, 8, 9, 10	12, 15
2 ... 10	1	6, 7, 10, 11	12, 15
4 ... 20	1	6, 7, 8, 11	12, 15
- 0.1 ... 0 ... + 0.1		6, 8, 9, 11	13, 14, 16
- 0.2 ... 0 ... + 0.2		6, 7, 9, 10	13, 14, 16
- 0.5 ... 0 ... + 0.5	2	7, 8, 10, 11	13, 14, 16
- 1 ... 0 ... + 1	2	7, 8, 9, 11	13, 14, 16
- 2 ... 0 ... + 2	2	6, 8, 9, 10	13, 14, 16
- 5 ... 0 ... + 5	1	10, 11	13, 14, 16
- 10 ... 0 ... + 10	1	6, 11	13, 14, 16
- 20 ... 0 ... + 20	1	8	13, 14, 16

11.2 Standard output ranges

Soldered jumpers are provided for the coarse setting of the output ranges and the fine adjustment is accomplished using the potentiometers "Zero" and "Span".

Current [mA]	Soldered jumpers		Voltage [V]	Soldered jumpers	
	Channel 1	Channel 2		Channel 1	Channel 2
0 ... 20	B120	B220	0 ... 10	B120 B122 B123	B220 B222 B223
4 ... 20	B121	B221	2 ... 10	B121 B122 B123	B221 B222 B223
± 20	—	—	± 10	B122 B123	B222 B223

11.3 Specific user output ranges

Units that have been configured for a specific user output range cannot be subsequently reconfigured.

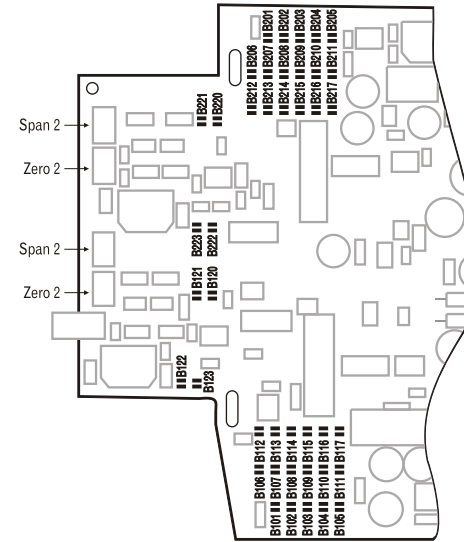

Fig. 8. Position of the soldered jumpers B..., Potentiometer "Zero" and "Span".

12. Commissioning

Switch on the measuring inputs and the power supply. The green LED lights continuously after switching on.



The power supply unit must be capable of supplying a brief current surge when switching on. The instrument presents a low impedance at the instant of switching which requires a current I_{start} of ...

... $I_{start} \geq 160$ mA for the version with a power supply range of 24 - 60 V DC/AC

or
... $I_{start} \geq 35$ mA for the version with a power supply range of 85 - 230 V DC/AC

13. Maintenance

No maintenance is required.

14. Releasing the isolating amplifier

Release the isolating amplifier from a top-hat rail as shown in Fig. 9.

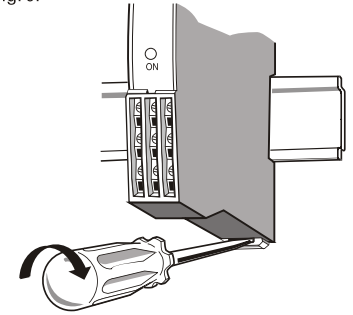

Fig. 9.

15. Dimensional drawings

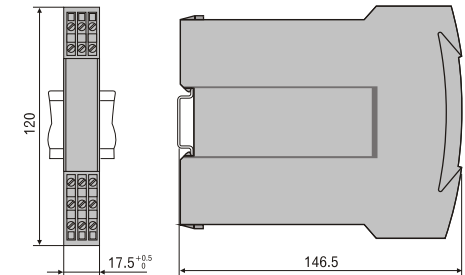

Fig. 10. *THETA 60I* Transducer *T* in housing S17 clipped onto a top-hat rail (35 x 15 mm or 35 x 7.5 mm, acc. To EN 50 022).

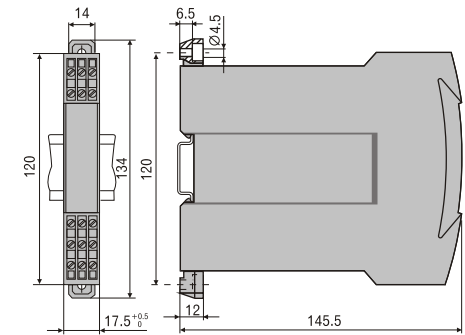

Fig. 11. *THETA 60I* Transducer in housing S17, screw hole mounting brackets pulled out.