

# Fast Response Presenter

## Comparison of full specification PPM meters and Fast Response Presenter range

The response curves below give a comparison of the full specification PPM meters with that of a Fast Response Presenter 19, 29 and 39.

A variation in over swing will occur from the nominal Presenter responses shown, as unlike the full specification PPM indicator where each meter is individually adjusted for ballistics, these fall within normal process parameters. In each case the FSD is 1mA. For the Presenter range the terminal resistance is  $465\Omega \pm 15\%$  whereas for the PPM meter it is  $600\Omega \pm 5\%$ .

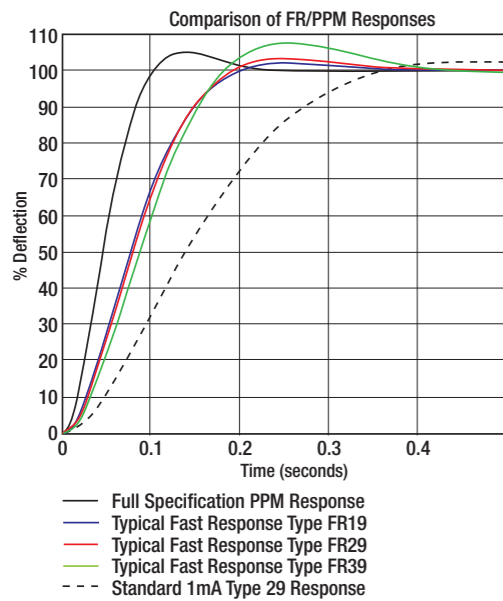

## Terminals

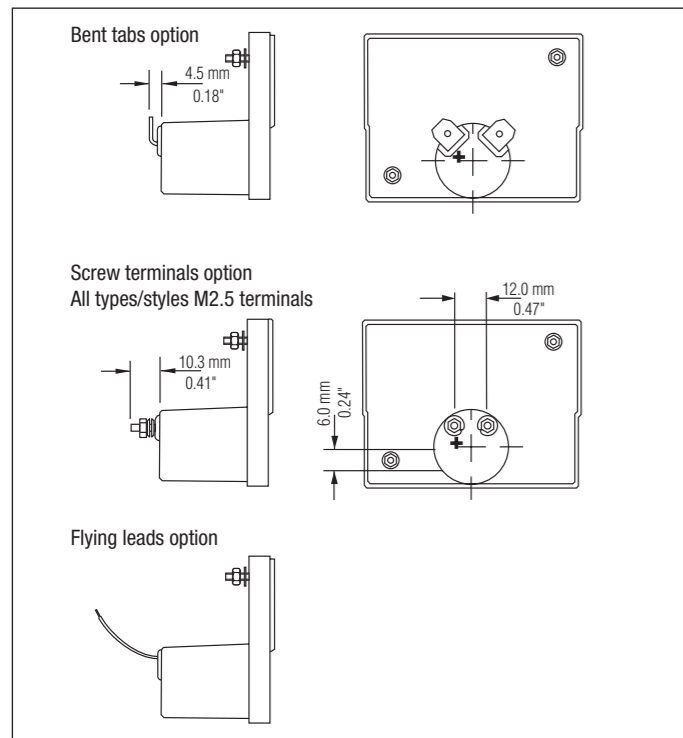

## Illumination

Illumination is available in either of the three forms below. Please contact the sales office for full information.

### Overhead

Available for types 19W, 19WF, 29W, 29WF, 39W, 39WF.  
Unit contains Ø6mm festoon style lamp available in 6V, 12V, or 24V.

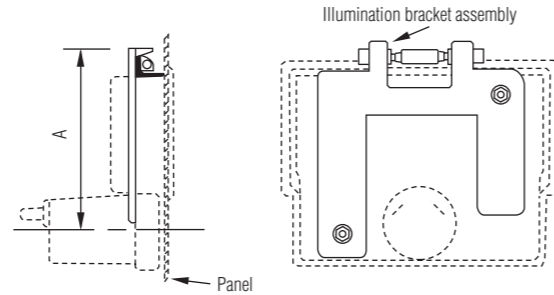

Type	Dimension A
FR19	33.5mm/1.33"
FR29	55.5mm/2.19"
FR39	68.5mm/2.69"

### Light box

Available for all styles for types 29, 39. The meter fixing studs occupy different positions and rectangular panel cut-outs are required for styles M, B. Drawings are available on request.

Unit is available with either festoon style or T1½ flanged lamps available in 6V, 12V, 24V. T1½ flanged LEDs are also available in either 12V or 24V. (One lamp on type 29, two lamps on type 39).

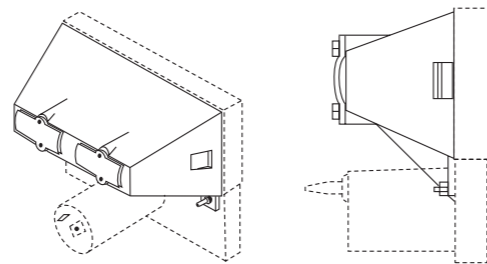

### LED Illumination

Internal LED illumination is also available for most sizes and types. Please contact the sales office for full information.

As part of our policy of continuous product improvement we reserve the right to change specifications at any time.

## Europe

Sifam Tinsley Instrumentation Ltd

Central Building, Woodland Close,  
Old Wood Trading EA, Torquay,  
Devon, England, TQ2 7BB

Tel : +44 (0) 1803 615139  
Fax : +44 (0) 1803 616800  
Email : sales@sifamtinsley.com  
Web : www.sifamtinsley.com  
: www.sifam.com



# Fast Response Presenter

## Types FR19, FR29, FR39

The Present or Fast Response range of analogue panel meters complements the proven and popular Industrial and Audio Level series. The range is available in three size each in four styles and offers a performance close to that of full specification PPM meters to meet today's broadcast market requirement for quality at affordable prices

## Features and benefits

- Choice of four styles available in each size
  - Simple back of panel mounting
  - Back of panel mounting with accompanying bezel
  - Front of panel mounting with lower mask
  - Front of panel mounting with full bezel
- Constructed with transparent acrylic front and high impact translucent rear body moulding. Masks and bezels are moulded in black ABS.
- Taut band core magnet movement incorporated as standard with compact 26mm diameter barrel. This rugged movement makes these meters equally suitable for portable or fixed applications. There is no calibration effect when mounted on a ferrous panel.

## Specification

A dc milliammeter offering performance close to that of full specification PPM meters to IEC 268-10. The general meter build conforms to the relevant parts of BS89, EN 60051 and IEC 60051.

## Pointers and dials

The combination of white tube pointer and flattened arc scale on a black dial results in an easy-to-read meter.

## Zero adjuster

Nomally positioned on the front of surface mounted styles (M and B types) or on the rear of behind panel styles (W and WF types). Other options may be specified.

## Certified drawings

Available on request.

## Operating Temperature

-25°C to +55°C.

## Illumination

Comprehensive options are available. Please refer to back page for more information.

## Terminals

6mm tabs are supplied as standard but threaded studs or flying leads are available. Please refer to back page for more information.

## Key Features

- Flexible styling — 3 sizes each in four styles
- High performance at affordable prices
- Illumination Options

Fast Response Presenter

## Presenter Style W

For back of panel mounting with only the scale and pointer visible.

Types: **FR19W, FR29W, FR39W**

Meter barrel cut out 27.0mm/1.06"  
Fixing studs M2.5x10.0mm/0.39"  
(except type 19: M2)

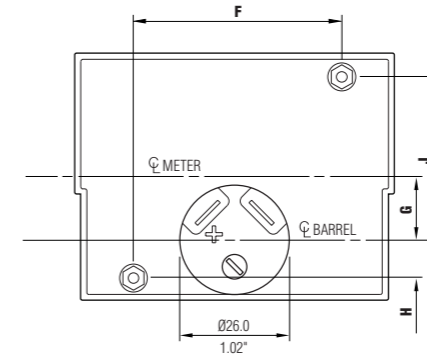
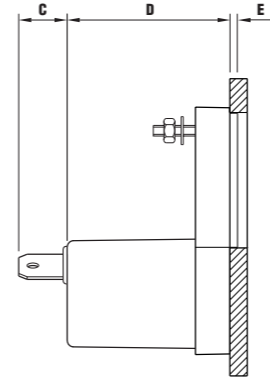
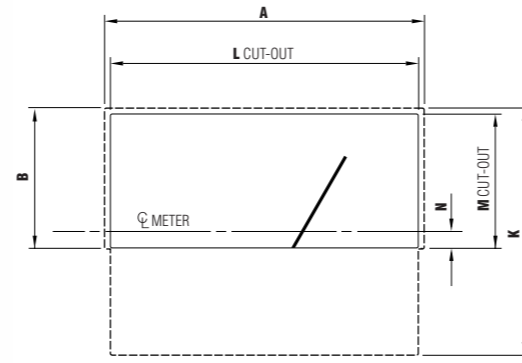

	19W		29W		39W	
	mm	inches	mm	inches	mm	inches
A	43.9	1.73	76.1	3.00	94.0	3.70
B	21.0	0.82	33.3	1.31	41.9	1.65
C	11.5	0.45	11.5	0.45	11.5	0.45
D	31.2	1.23	30.5	1.20	30.2	1.18
E	7.5	0.30	10.0	0.39	11.0	0.43
F	32.0	1.26	47.8	1.88	57.2	2.25
G	4.7	0.18	15.0	0.59	20.9	0.78
H	Fixing studs on horizontal plan, 7.0mm/0.28" above barrel CL.		9.7	0.38	8.6	0.34
J			38.0	1.50	48.5	1.90
K	37.9	1.49	58.8	2.32	74.0	2.91
L	42.4	1.67	73.7	2.90	91.5	3.60
M	20.2	0.79	32.3	1.27	40.5	1.59
N	2.0	0.08	3.9	0.15	5.70	0.22

## Presenter Style WF

For back of panel mounting with bezel and with only the scale and pointer visible.

Types: **FR19WF, FR29WF, FR39WF**

Max panel thickness 4.0mm/0.16"  
(except type 19: 3.0mm/0.12")  
Meter barrel cut out 27.0mm/1.06"  
Fixing studs M2.5x10.0mm/0.39"  
(except type 19: M2)

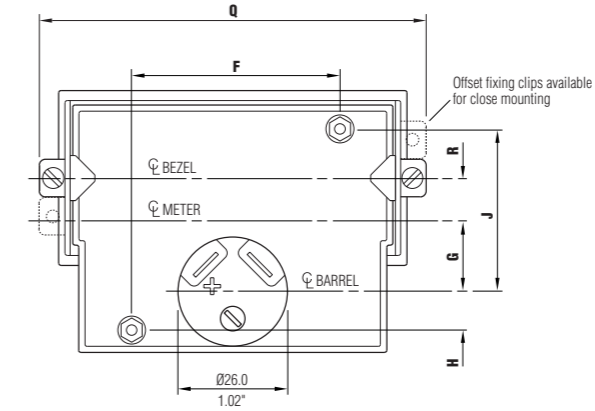
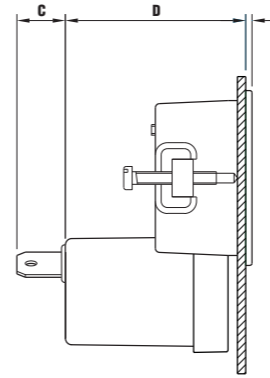
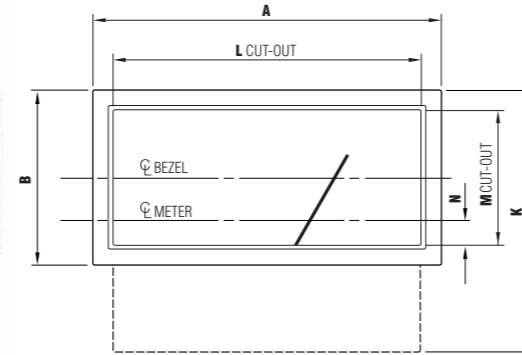
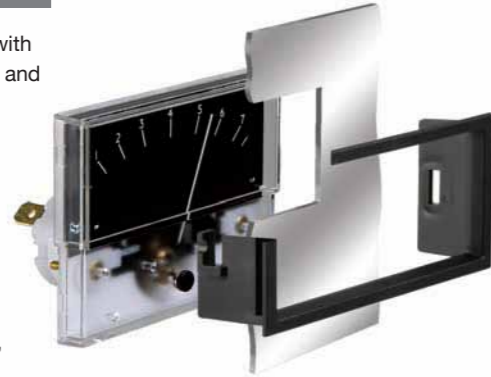

	19WF		29WF		39WF	
	mm	inches	mm	inches	mm	inches
A	49.2	1.94	82.8	3.26	101.0	3.98
B	27.0	1.06	41.6	1.64	50.5	1.99
C	11.5	0.45	11.5	0.45	11.5	0.45
D	40.8	1.61	42.9	1.69	43.4	1.71
E	1.5	0.06	1.5	0.06	1.6	0.06
F	32.0	1.26	47.8	1.88	57.2	2.25
G	6.10	0.24	16.7	0.66	28.7	1.13
H	Fixing studs on horizontal plan, 7.0mm/0.28" above barrel CL.		9.70	0.38	8.6	0.34
J			38.0	1.50	48.5	1.90
K	40.6	1.60	62.2	2.45	76.1	2.99
L	47.0	1.85	80.0	3.26	98.0	3.86
M	24.0	0.95	37.0	1.46	46.0	1.81
N	5.2	0.20	8.10	0.32	10.2	0.40
Q	58.5	2.30	90.6	3.57	108.6	4.28
R	6.8	0.27	10.3	0.41	12.8	0.50

## Presenter Style M

For front of panel mounting with lower mask.

Types: **FR19M, FR29M, FR39M**

Max panel thickness 6.0mm/0.24"  
Meter barrel cut out 27.0mm/1.06"  
Fixing studs M2.5x10.0mm/0.39"  
(except type 19: M2)

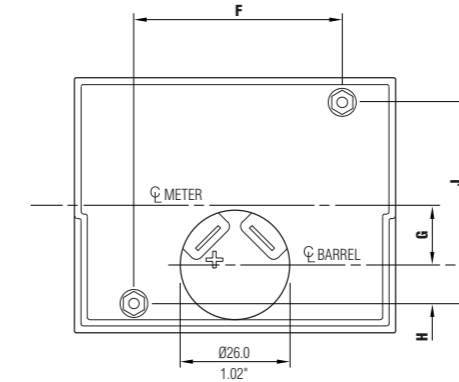
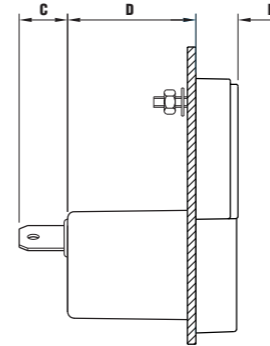
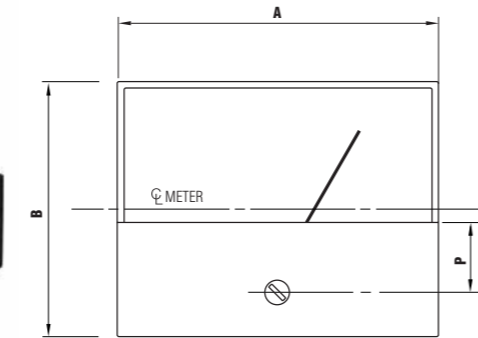

	19M		29M		39M	
	mm	inches	mm	inches	mm	inches
A	43.9	1.73	76.1	3.00	94.0	3.70
B	38.8	1.53	60.3	2.37	74.0	2.91
C	11.5	0.45	11.5	0.45	11.5	0.45
D	31.2	1.23	30.5	1.20	30.2	1.18
E	7.5	0.30	10.0	0.39	11.0	0.43
F	32.0	1.26	47.8	1.88	57.2	2.25
G	4.2	0.17	14.2	0.56	20.0	0.79
H	Fixing studs on horizontal plan, 7.0mm/0.28" above barrel CL.		9.7	0.38	8.6	0.34
J			38.0	1.50	48.5	1.90
P	9.9	0.39	16.1	0.63	20.4	0.80

## Presenter Style B

For front of panel mounting with full bezel

Types: **FR19B, FR29B, FR39B**

Max panel thickness 6.0mm/0.24"  
Meter barrel cut out 27.0mm/1.06"  
Fixing studs M2.5x10.0mm/0.39"  
(except type 19: M2)

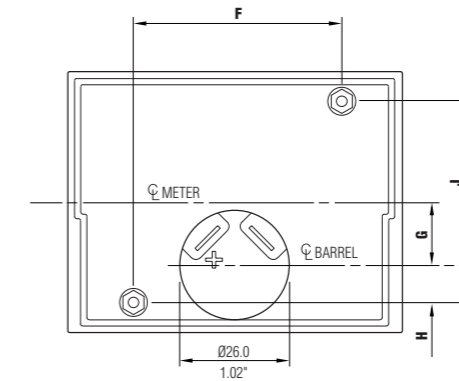
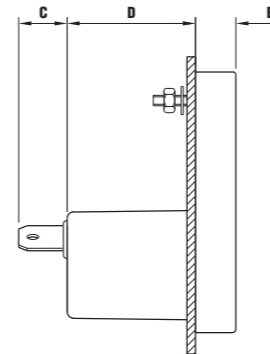
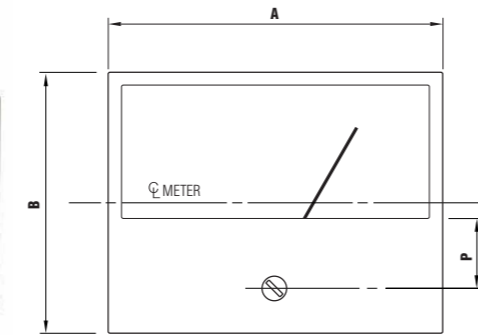

	19B		29B		39B	
	mm	inches	mm	inches	mm	inches
A	46.0	1.81	79.5	3.13	97.5	3.84
B	40.0	1.57	61.9	2.44	76.4	3.01
C	11.5	0.45	11.5	0.45	11.5	0.45
D	31.2	1.23	30.5	1.20	30.2	1.18
E	7.50	0.30	10.0	0.39	11.0	0.43
F	32.0	1.26	47.8	1.88	57.2	2.25
G	4.8	0.19	15.0	0.59	20.8	0.82
H	Fixing studs on horizontal plan, 7.0mm/0.28" above barrel CL.		9.7	0.38	8.6	0.34
J			38.0	1.50	48.5	1.90
P	9.9	0.39	16.1	0.63	20.4	0.80