



 **Fenner Drives**<sup>®</sup>

**PULLEYS, SPROCKETS &  
TENSIONERS**



**PowerMax**<sup>™</sup> **TMax**<sup>®</sup>



The PowerMax™ line of idler pulleys and sprockets offers superior composite design for years of successful service. PowerMax Idler Pulleys and Sprockets are available in a wide range of sizes for flat, round and V-belts and industry standard pitch chains. They are perfect for use as high-speed idlers on conveyors, packaging equipment, lawn and garden equipment, floor cleaning machines and in many other power transmission applications.



When used in power transmission drives, all V-belts and roller chains will elongate significantly over time if not properly maintained. This can cause energy losses for belt and chain drives. In addition, incorrect belt or chain tension will lead to increased downtime, lower equipment productivity and inflated maintenance costs. To achieve optimum drive performance, correct drive belt or chain tension must be maintained. The solution? A self-adjusting T-Max® Tensioner from Fenner Drives. T-Max automatic tensioners eliminate the need for regular manual retensioning of drives. The risk of inadvertently over-tensioning drive components is avoided and overall drive operating efficiency is enhanced.

### **Count on Fenner Drives®. We've got the right product for your application.**

With over 100 years of manufacturing, technical and commercial expertise, Fenner Drives is a global leader in value-adding, problem-solving products for conveying and power transmission applications. Recognized widely for our expertise and innovation, we blend reliability, quality and value in our products while providing unsurpassed technical support and service.



## INDEX

**TMax**  
BELT & CHAIN TENSIONERS



<b>TMax</b> .....	<b>4</b>
Rotary Belt and Chain Tensioners .....	4-5
Linear Chain Tensioners .....	6
Tensioners, Pulleys and Sprockets Assemblies .....	7

**PowerMax**  
PULLEYS & IDLERS



<b>PowerMax</b> .....	<b>8</b>
Engineering Data .....	8
Belt Pulleys and Idlers .....	9-10
Pulleys, Carriage Roller and Sprockets .....	11
Mounting Adapters and Pillow Blocks .....	12



## T-Max Belt & Chain Tensioners

Automatically take up the slack and avoid the risk of over-tensioning drive components to enhance overall drive operating efficiency.

- Constructed from high-quality materials for proven durability
- Wide range of tensioners to handle single and multiple strand belt and chain drives
- Available in linear and rotary (light-duty, medium and heavy-duty) series
- A range of sizes and mounting styles available to best fit your application



# T-Max® Belt & Chain Tensioners

## ROTARY BELT & CHAIN TENSIONERS

### RT1000 Series \*†

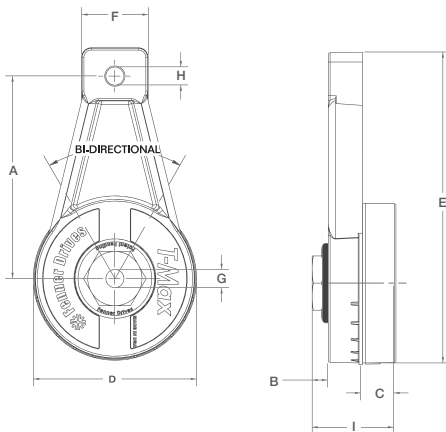

Part Number	Dimensions (inches)										Rotation (degrees)	Force ‡ (lbs)
	A	B	C	D	E	F	G	H	I			
RT1001	3.50	0.29	0.59	2.76	5.37	1.15	3/8-16	3/8-16	1.45	15	16	
										30	23	
										45	30	
RT1003	3.50	0.29	0.59	2.76	5.37	1.15	0.40	3/8-16	1.45	15	16	
										30	23	
										45	30	
RT1054ZF <small>Zerk fitted to apply grease to the spring cavity.</small>	3.50	0.29	0.59	2.76	5.37	1.15	3/8-16	3/8-16	1.45	15	16	
										30	23	
										45	30	
RT1056ZF <small>Zerk fitted to apply grease to the shaft area.</small>	3.50	0.29	0.59	2.76	5.37	1.15	3/8-16	3/8-16	1.45	15	16	
										30	23	
										45	30	

### RT1600 Series \*†

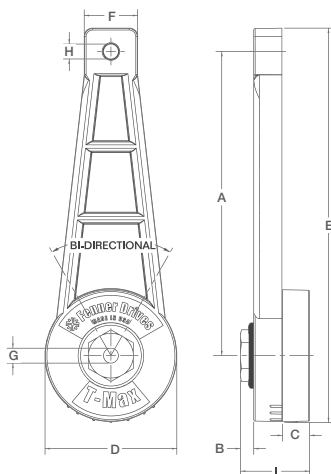

Part Number	Dimensions (inches)										Rotation (degrees)	Force ‡ (lbs)
	A	B	C	D	E	F	G	H	I			
RT1601-L	6.37	0.29	0.59	2.76	8.24	1.12	3/8-16	3/8-16	1.45	15	10	
										30	13	
										45	16	
RT1603-L	6.37	0.29	0.59	2.76	8.24	1.12	0.40	3/8-16	1.45	15	10	
										30	13	
										45	16	
RT1601	6.37	0.29	0.59	2.76	8.24	1.12	3/8-16	3/8-16	1.45	15	20	
										25	23	
										35	26	
RT1603	6.37	0.29	0.59	2.76	8.24	1.12	0.40	3/8-16	1.45	15	20	
										25	23	
										35	26	

### RT3000 Series \*

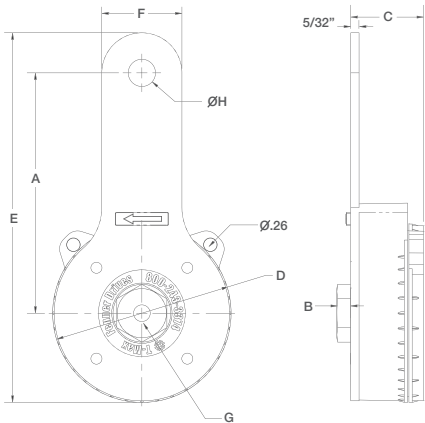

Part Number	Dimensions (inches)								Rotation (degrees)	Force ‡ (lbs)
	A	B	C	D	E	F	G	H		
RT3000	4.50	0.28	1.35	3.34	6.92	1.50	3/8-16	0.51	0 - 70	0 - 42
RT3001	4.50	0.28	1.35	3.34	6.92	1.50	0.40	0.51	0 - 70	0 - 42

### RT4100 Series \*†

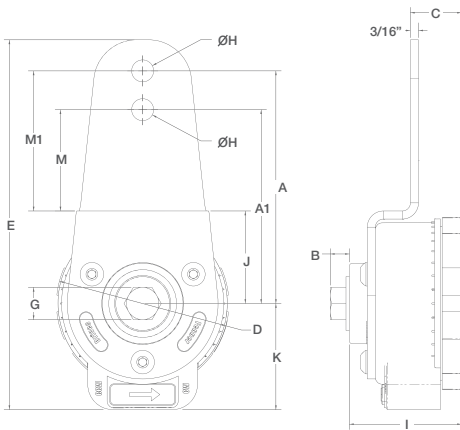

Part Number	Dimensions (inches)													Rotation (degrees)	Force ‡ (lbs)
	A	A1	B	C	D	E	G	H	I	J	K	M	M1		
RT4100	5.40	4.50	0.47	1.19	4.00	8.58	1/2 - 13	0.51	2.60	2.15	2.46	2.35	3.25	0 - 85	0 - 85
RT4101	5.40	4.50	N/A	1.19	4.00	8.58	0.51	0.51	2.60	2.15	2.46	2.35	3.25	0 - 85	0 - 85

### RT4900 Series \*†

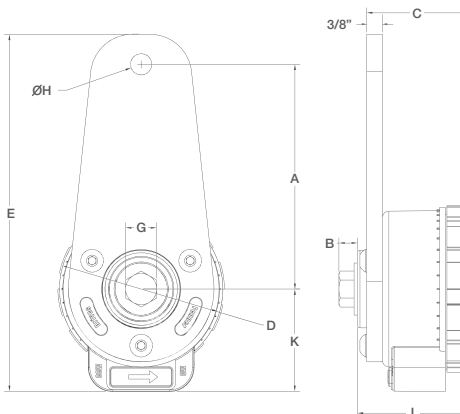

Part Number	Dimensions (inches)									Rotation § (degrees)	Force § (lbs)
	A	B	C	D	E	G	H	I	K		
RT4900	5.40	N/A	2.37	4.00	8.58	0.51	0.51	2.60	2.46	0 - 85	0 - 70
RT4902	5.40	0.47	2.37	4.00	8.58	1/2 - 13	0.51	2.60	2.46	0 - 85	0 - 70

\* Maximum load no more than 1½" distance from front face of tensioner arm to centerline of idler.  
 † Requires a fixed head, hook style spanner wrench for tensioning (supplied with unit).  
 ‡ Dimension A: 1° rotation = .83 lb. force.  
 Dimension A1: 1° rotation = 1 lb. force. All forces (lbs.) are nominal.  
 § 1° rotation = .83 lb. force. All forces (lbs.) are nominal.

### TMAX TENSIONER BRACKET



Part Number	Bracket Compatible with	Base Compatible with
B1265	T-MAX RT1000 T-MAX RT3000	NEMA 48, 56, 143T IEC 63, 71, 80, 90s

# T-Max® Chain Tensioners

LINEAR CHAIN TENSIONERS

## CT Series: CT1100, CT2100 & CT3100†

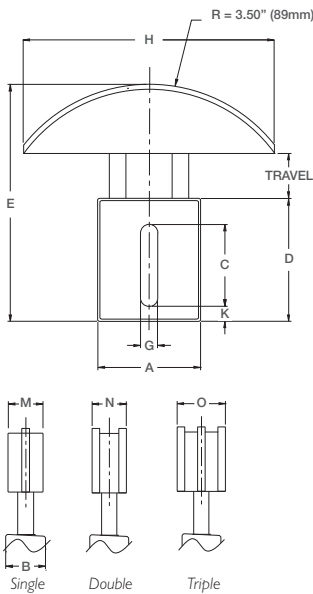

Series	Tensioner Body Dimensions*								Travel (in)	Force † (lbs)
	A	B	C	D	E	G	H	K		
<b>INCH</b>										
CT11XX	2.31	0.98	1.82	2.91	5.6	0.41	5.5	0.46	1.05	15 - 40
CT21XX	2.95	1.18	2.27	3.52	6.4	0.49	5.5	0.45	1.20	20 - 60
CT31XX	3.54	1.35	2.91	4.25	7.5	0.53	5.5	0.49	1.50	45 - 100

Part Number	Single Chain		Double Chain			Triple Chain			Travel (in)	Force † (lbs)
	Chain	M*	Part Number	Chain	N*	Part Number	Chain	O*		
<b>INCH</b>										
CT1101-L	#35	0.79	CT1103-L	#35	0.79	CT1105-L	#35	0.98	1.05	5 - 30
CT1101	#35	0.79	CT1103	#35	0.79	CT1105	#35	0.98	1.05	15 - 40
CT1102	#40	0.79	CT1104	#40	0.79	CT1106	#40	1.37	1.05	15 - 40
CT2101	#50	0.87	CT2103	#50	0.98	CT2105	#50	1.75	1.20	20 - 60
CT2102	#60	0.87	CT2104	#60	1.37				1.20	20 - 60
CT3101	#80	0.98	CT3103	#80	1.75				1.50	45 - 100
CT3102	#100	0.98							1.50	45 - 100
CT3102-H	#100	0.98							1.00	30 - 200
CT3196	#81X	2.15							1.50	45 - 100
<b>METRIC</b>										
CT1111-L	06B	20	CT1113-L	06B	20				27	22 - 133
CT1111	06B	20	CT1113	06B	20				27	67 - 178
CT1112	08B	20	CT1114	08B	20				27	67 - 178
CT2111	10B	22	CT2112	10B	25				31	89 - 267
CT2109	12B	22	CT2110	12B	35				31	89 - 267
CT3111	16B	25	CT3113	16B	44				38	200 - 445
CT3112	20B	25							38	200 - 445
CT3112-H	20B	25							25	134 - 890

## CT Series: CT1200, CT2200 & CT3200†

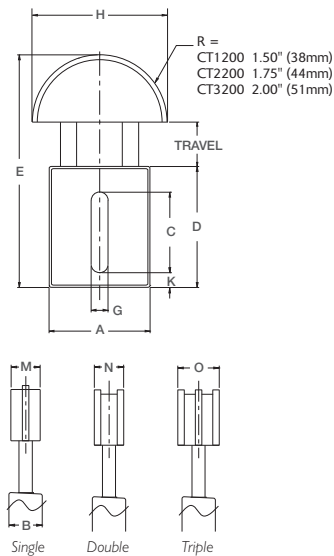

Series	Tensioner Body Dimensions*								Travel (in)	Force † (lbs)
	A	B	C	D	E	G	H	K		
<b>INCH</b>										
CT12XX	2.31	0.98	1.82	2.91	5.47	0.41	3	0.46	1.05	15 - 40
CT22XX	2.95	1.18	2.27	3.52	6.47	0.49	3.5	0.45	1.20	20 - 60

Part Number	Single Chain		Double Chain			Triple Chain			Travel (in)	Force † (lbs)
	Chain	M*	Part Number	Chain	N*	Part Number	Chain	O*		
<b>INCH</b>										
CT1201-L	#35	1.00	CT1203-L	#35	0.79	CT1205-L	#35	0.98	1.05	5 - 30
CT1201	#35	1.00	CT1203	#35	0.79	CT1205	#35	0.98	1.05	15 - 40
CT1202	#40	1.00	CT1204	#40	0.79	CT1206	#40	1.37	1.05	15 - 40
CT2201	#50	1.00	CT2203	#50	0.98	CT2205	#50	1.75	1.20	20 - 60
CT2202	#60	1.00	CT2204	#60	1.37				1.20	20 - 60
CT3201	#80	0.98	CT3203	#80	1.75				1.50	45 - 100
CT3202	#100	0.98							1.50	45 - 100
CT3202-H	#100	0.98							1.00	30 - 200
<b>METRIC</b>										
CT1211-L	06B	20	CT1213-L	06B	20				27	22 - 133
CT1211	06B	20	CT1213	06B	20				27	67 - 178
CT1212	08B	20	CT1214	08B	20				27	67 - 178
CT2208	10B	22	CT2209	10B	25				31	89 - 267
CT2206	12B	22	CT2207	12B	35				31	89 - 267
CT3211	16B	25	CT3213	16B	44				38	200 - 445
CT3212	20B	25							38	200 - 445
CT3212-H	20B	25							25	134 - 890

\* Inch dimensions are in inches; metric dimensions are in millimeters.

† These tensioners can be used on chain sizes up to ANSI #160 or BS/DIN #24B.

Contact Fenner Drives Applications Engineering group at [AE@fennerdrives.com](mailto:AE@fennerdrives.com) for head dimensions.

‡ All forces are nominal.

# T-Max® Tensioner Assemblies

TENSIONERS, PULLEYS AND SPROCKETS ASSEMBLIES

## T-Max® Tensioner/Pulley Assembly



Assembly Part Number	Component	Component Part Number	
<b>A Section Belt</b>			
FS0578	Tensioner	RT1001	Force Range: 0-30 lb
	Pulley	VA3001	3" OD
FS0581ZF	Tensioner	RT1001	Force Range: 0-30 lb Zerk fitted to apply grease to the spring cavity.
	Pulley	VA3001	3" OD
FS0667ZF	Tensioner	RT1001-L	Force Range: 0-30 lb Zerk fitted to apply grease to the shaft area.
	Pulley	VX3012	3" OD
FS0524	Tensioner	RT3001	Force Range: 0-42 lb
	Pulley	VA3001	3" OD

## T-Max Tensioner/Pulley Assembly



Assembly Part Number	Component	Component Part Number	
<b>B Section Belt</b>			
FS0566	Tensioner	RT3001	Force Range: 0-42 lb
	Pulley	VA5001	5" OD
FS0608	Tensioner	RT3000	Force Range: 0-42 lb
	Pulley	VX0285	4" OD Double Groove

## T-Max Tensioner/Sprocket Assemblies

Assembly Part Number	Component	Component Part Number	Rotation (Degrees)	Force (lbs)
<b>#35 Chain</b>				
FS0142	Tensioner Sprocket	RT1001 CS3502	15	16
			30	23
			45	30
FS0658	Tensioner Sprocket	RT1601-L CS3502	15	10
			30	13
			45	16
<b>#40 Chain</b>				
FS0651	Tensioner Sprocket	RT1001 CS4002	15	16
			30	23
			45	30
FS0652	Tensioner Sprocket	RT1601 CS4002	15	20
			25	23
			35	26
FS0644	Tensioner Sprocket	RT1601-L CS4002	15	10
			30	13
			45	16
FS0557	Tensioner Sprocket	RT3001 CS4002	0 - 70	0 - 42

Assembly Part Number	Component	Component Part Number	Rotation (Degrees)	Force (lbs)
<b>#50 Chain</b>				
FS0653	Tensioner Sprocket	RT1001 CS5002	15	16
			30	23
			45	30
FS0654	Tensioner Sprocket	RT1601 CS5002	15	20
			25	23
			35	26
FS0659	Tensioner Sprocket	RT1601-L CS5002	15	10
			30	13
			45	16
FS0567	Tensioner Sprocket	RT3001 CS5002	0 - 70	0 - 42
<b>#60 Chain</b>				
FS0655	Tensioner Sprocket	RT1001 CS6002	15	16
			30	23
			45	30
FS0656	Tensioner Sprocket	RT1601 CS6002	15	20
			25	23
			35	26
FS0568	Tensioner Sprocket	RT3001 CS6002	0 - 70	0 - 42
<b>#80 Chain</b>				
FS0657	Tensioner Sprocket	RT1001 CS8002	15	16
			30	23
			45	30



Fenner Drives has several tensioner/sprocket assemblies not shown here. Contact us for availability.

# PowerMax™

## The PowerMax Advantage

Fenner Drives is the industry leader in molded composite solutions for industrial power transmission and material handling applications. PowerMax composite products are used where dependability counts most.

- High-strength glass reinforced composite idlers and pulleys are available in a wide range of sizes for flat, round and V-belts.
- Our composite products are a lightweight, corrosion resistant alternative to steel, aluminum and cast iron.



## PowerMax™ Engineering Data

Almost all PowerMax Pulleys use precision 6203-2RS chrome-alloy steel radial ball bearings (exceptions are noted). These bearings meet all ABEC-1 standards. Our bearings utilize two rubber wiping seals to keep the grease in and contaminants out. See chart for standard load ratings.

Bearing Properties	
Type	6203-2RS
Seals	Rubber Wiping
Fit	ABEC-1 "C4" Internal Clearance
Lubrication	Mobil Polyrex EM or equivalent NLGI No. 2 (30% +/- 5% Fill)
Service Temperature	-20° – 350°F (-30° – 180°C)
Basic Dynamic Load	2150 lbs. (9563N)

6203 Radial Load Ratings											
Speed (RPM)	33	100	200	300	500	1000	1500	1800	2500	3600	5000
Load (lbs)	2141	1480	1175	1026	866	687	601	565	507	449	402
Load (N)	9523	6583	5226	4566	3852	3058	2672	2514	2254	1996	1789

Load Ratings based on 500 HR minimum L<sub>10</sub> life.

Bearings are also available in stainless steel, with trash seals and shields.

## Bearing Life

How long a bearing will last in an application depends on two variables: first, the bearing's physical properties (material, design, method of manufacture); and second, the conditions of operation (load, speed, temperature, lubrication). Although it is not possible to predict the exact life of a bearing, the designer can calculate the "L10 Life" of a bearing. L10 is the life, in hours or revolutions, that 90% of a group of bearings will complete or exceed. The equations for calculating L10 life are:

- Revolutions:  $L_{10} = \left(\frac{C}{P}\right)^3 \times 10^6$

- Hours:  $L_{10} = \left(\frac{C}{P}\right)^3 \times \frac{16667}{N}$

- Where:

L<sub>10</sub> = Rating Life

C = Basic Dynamic Capacity

P = Radial Load in lbs.

N = Speed in RPM

## Material Properties

Fenner Drives uses engineering composites, which ensure the highest level of performance and consistent strength. Our standard material is 33% glass reinforced nylon 6/6. The combination of high strength, temperature resistance and abrasion resistance makes nylon a versatile engineering thermoplastic.

33% GLASS-REINFORCED NYLON 6/6, dry as molded		
PROPERTY	ASTM CODE	VALUE
Tensile Strength at Break	D638	20,000 psi
Flexural Modulus	D790	1,300,000 psi
Heat Deflection Temp @ 264 psi	D648	480°F (249°C)
Continuous Service Temp. (Min. – Max.)	N/A	32° to 225°F (0° to 107°C)
Izod Impact Strength (notched 1/8")	D256	1.3 to 1.8 ft.-lb/in. of notch

Data listed was generated using molded specimens tested under standard conditions. Many of the mechanical properties can be influenced by processing conditions, environmental factors and the application of stress. Therefore, this data characterizes typical production material, and should not be used either to establish specification limits or alone as the basis for engineering design.



## PowerMax™ V Belt Idlers

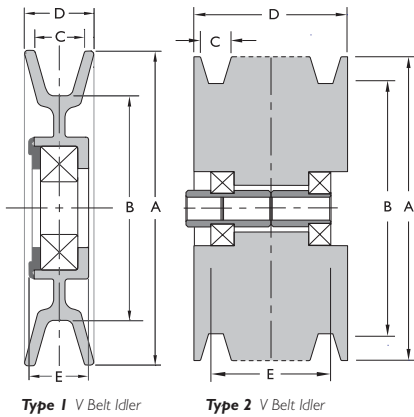

Part Number	Type	Grooves	Dimensions (inches)					Belt Size	Bearing Type	Bore Sizes
			A	B	C	D	E			
VA3001†	1	1	3.0	2.0	0.5	0.7	0.81	A	6203-2RS	17mm
VA3002	1	1	3.0	1.84	0.63	0.78	0.81	B	6203-2RS	17mm
VA4001	1	1	3.98	2.99	0.5	0.7	0.81	A	6203-2RS	17mm
VA4002	1	1	4.0	2.84	0.64	0.86	0.81	B	6203-2RS	17mm
VA5001	1	1	5.04	3.84	0.65	0.8	0.82	B	6203-2RS	17mm
VA6001	1	1	6.03	5.12	0.5	0.72	0.81	A	6203-2RS	17mm
VA6250†	1	1	6.25	5.0	0.61	0.95	0.72	A/B	6203-2RS	17mm
VA7501	1	1	7.5	6.6	0.54	0.72	0.75	A	6203-2RS	17mm
V2B6280	2	2	6.28	5.18	0.64	1.72	1.85	B/5V	6203-2RS	.510/.520
V3B6280	2	3	6.28	5.18	0.64	2.44	2.58	B/5V	6203-2RS	.510/.520
V4B6280	2	4	6.28	5.18	0.64	3.16	3.33	B/5V	6203-2RS	.510/.520

## PowerMax V Belt Idlers, Single Flange

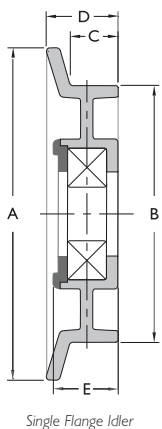

Part Number	Dimensions (inches)					Belt Size	Bearing Type	Bore Sizes
	A	B	C	D	E			
VA3600	3.6	2.84	0.59	0.84	0.8	B	6203-2RS	17mm
VA4130*	4.13	3.23	0.58	0.86	0.81	B	6203-2RS	17mm

## PowerMax Flat Belt Idlers, Flangeless

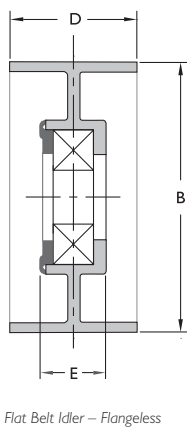

Part Number	Type	Crown	Dimensions (inches)					Belt Size	Bearing Type	Bore Size
			A	B	C	D	E			
FA2009†	1	No	—	2.0	—	1.0	0.47	13/16"	6203-2RS	17mm
FA2010†	1	No	—	1.98	—	0.75	0.47	5/8"	6203-2DD	17mm
FA2700†	1	No	—	2.71	—	1.05	0.67	7/8"	6203-2RS	17mm
FA2900*	1	Yes	—	2.91	—	1.22	0.76	1"	6203-2RS	17mm
FA3003*	1	No	—	2.96	—	1.09	0.76	29/32"	6203-2RS	17mm
FA3250†	1	No	—	3.2	—	1.01	0.67	13/16"	6203-2DD	17mm
FA4502	1	No	—	4.5	—	1.21	0.82	1"	6203-2RS	17mm
FX0002*‡	1	Yes	—	2.33	—	1.39	—	11/8"	6205-2RS	1"

\* Minimums may apply  
 † Insertion molded bearing  
 ‡ Special 1" bore bearing with extended inner-race

## PowerMax™ Flat Belt Idlers, 2 Flange

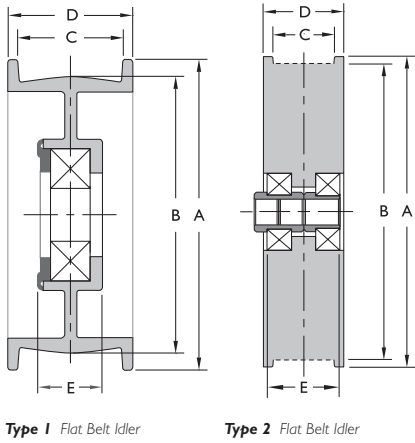

Part Number	Type	Crown	Dimensions (inches)					Belt Size	Bearing Type	Bore Size
			A	B	C	D	E			
FA2001†	1	Yes	2.07	1.88	1.37	1.54	0.47	1 1/8"	6203-2RS	17mm
FA2002†	1	Yes	2.35	1.99	0.98	1.15	0.47	7/8"	6203-2RS	17mm
FA2003	1	No	2.76	1.94	0.82	1.15	0.75	5/8"	6203-2RS	17mm
FA2501†	1	No	2.48	1.97	1.55	1.85	0.72	11/4"	6203-2RS	17mm
FA2750†	1	Yes	2.75	1.97	1.09	1.4	0.67	29/32"	6203-2RS	17mm
FA2751	1	Yes	2.75	2.52	1	1.22	0.8	13/16"	6203-2RS	17mm
FA3002	1	Yes	3	2.5	1.02	1.31	0.76	7/8"	6203-2RS	17mm
FA3251†	1	Yes	3.24	2.97	1.04	1.2	0.67	7/8"	6203-2DD	17mm
FA3301†	1	Yes	3.38	2.97	1.38	1.67	0.78	11/8"	6203-2RS	17mm
FA3501	1	Yes	3.5	3	0.77	1.09	0.76	5/8"	6203-2RS	17mm
FA3502	1	Yes	3.5	3	1	1.22	0.76	13/16"	6203-2RS	17mm
FA3504	1	Yes	3.48	2.98	0.69	0.9	0.76	1/2"	6203-2RS	17mm
FA3750†	1	Yes	3.75	2.96	1.09	1.38	0.67	29/32"	6203-2RS	17mm
FA3751†	1	Yes	3.8	3.25	1.03	1.24	0.67	7/8"	6203-2RS	17mm
FA4501	1	Yes	4.5	4	1.09	1.39	0.76	29/32"	6203-2RS	17mm
FA4750†	1	Yes	4.75	3.96	1.09	1.38	0.67	29/32"	6203-2RS	17mm
FA5501†	1	Yes	5.56	5.03	1.02	1.29	0.72	7/8"	6203-2RS	17mm
FX0001‡	1	Yes	2.75	2.37	1.07	1.39	—	29/32"	6205-2RS	1"
F1B6280	2	No	6.28	6	1.22	1.63	1.63	1"	6203-2RS	.510/.520
F2B6280	2	No	6.28	6	2.1	2.5	2.5	2"	6203-2RS	.510/.520
F3B6280	2	No	6.28	6	2.91	3.31	3.31	2 3/4"	6203-2RS	.510/.520
F4B6280	2	No	6.28	6	3.85	4.25	4.25	3 3/4"	6203-2RS	.510/.520

## PowerMax Round Belt Idlers

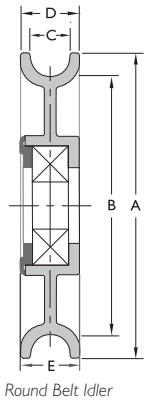

Part Number	Dimensions (inches)					Radius	Maximum Belt Size	Bearing Type	Bore Sizes
	A	B	C	D	E				
RA3001	3.05	2.45	0.4	0.61	0.81	0.19	3/8"	6203-2RS	17mm
RA3002	3.05	2.45	0.42	0.61	0.63	0.21	13/32"	6203-2RS	17mm
RA3501	3.5	2.75	0.53	0.76	0.76	0.26	1/2"	6203-2RS	17mm
RA3502	3.5	2.75	0.44	0.76	0.76	0.19	3/8"	6203-2RS	17mm
RA4101	4.12	3.5	0.53	0.68	0.72	0.26	1/2"	6203-2RS	17mm
RA4801	4.8	4	0.53	1	0.77	0.28	1/2"	6203-2RS	17mm
RA4802	4.82	4	0.73	1.06	0.77	0.36	11/16"	6203-2RS	17mm
RA5502†	5.38	4.62	0.38	0.56	0.7	0.19	3/8"	6203-2RS	17mm
SMALL SERIES									
RA1850†	1.84	1.39	0.4	0.63	0.63	0.16	5/16"	6902-2RS	15mm
RA2540	2.54	1.9	0.44	0.63	0.63	0.16	5/16"	6902-2RS	15mm

## PowerMax Cable Pulleys

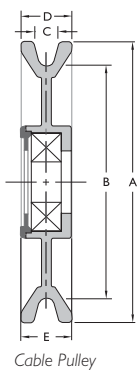

Part Number	Dimensions (inches)					Maximum Cable Size	Bearing Type	Bore Size
	A	B	C	D	E			
RA2701	2.75	2.43	0.23	0.54	0.82	5/32"	6203-2RS	17mm
RA3503†	3.55	2.73	0.39	0.8	0.77	1/4"	6203-2RS	17mm
RA3504	3.5	2.81	0.31	0.65	0.77	7/32"	6203-2RS	17mm
RA4501†	4.46	3.74	0.38	0.86	0.77	1/4"	6203-2RS	17mm
RA4502†	4.46	3.74	0.38	0.86	0.77	3/16"	6203-2RS	17mm
RA5001	5	4.31	0.31	0.65	0.73	3/16"	6203-2RS	17mm
RA5501†	5.5	4.86	0.22	0.53	0.6	5/32"	6203-2RS	17mm
RA6001	6	5.2	0.4	0.8	0.8	1/4"	6203-2RS	17mm

# PowerMax™ Pulleys, Carriage Roller and Sprockets

THE POWERMAX ADVANTAGE

## PowerMax™ Sprockets

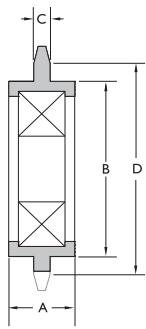

Sprocket

Part Number	Chain #	# Teeth	Nominal O.D. (in)	Pitch Diameter (in)	Dimensions (inches)			Bearing Type	Bore Size
					A	B	C		
CS3502†	35	19	2.48	2.28	0.67	1.78	0.164	6203-2RS	17mm
CS4002†	40	17	2.98	2.72	0.67	1.78	0.279	6203-2RS	17mm
CS4003†	40	17	2.98	2.72	0.67	1.78	0.279	6203-2RS-10	5/8"
CS4006*†	40	17	2.98	2.72	0.67	1.78	0.279	6203-2RS-12	3/4"
CS5002†	50	15	3.34	3.01	0.67	1.78	0.343	6203-2RS	17mm
CS5004†	50	15	3.34	3.01	0.67	1.78	0.343	6203-2RS-10	5/8"
CS5005*†	50	15	3.34	3.01	0.67	1.78	0.343	6203-2RS-12	3/4"
CS6002†	60	13	3.52	3.14	0.67	1.78	0.449	6203-2RS	17mm
CS6003†	60	13	3.52	3.14	0.67	1.78	0.449	6203-2RS-10	5/8"
CS6004†	60	13	3.52	3.14	0.67	1.78	0.449	6203-2RS-12	3/4"
CS8002†	80	12	4.39	3.86	0.67	1.78	0.58	6203-2RS	17mm
CS8003†	80	12	4.39	3.86	0.67	1.78	0.58	6203-2RS-10	5/8"
CS8004†	80	12	4.39	3.86	0.67	1.78	0.58	6203-2RS-12	3/4"

## PowerMax Carriage Rollers

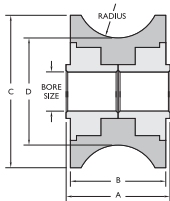

Type 1

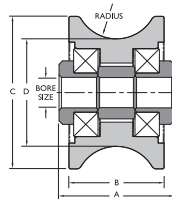

Type 2

Part Number	Type	Dimensions (inches)				Radius	Bore Sizes
		A	B	C	D		
RA2002	1	1.36	1.2	1.95	1.37	0.53"	1/2"
RA2004	1	1.48	1.2	1.95	1.37	0.53"	1/2"
RX0219	2	1.48	1.2	1.95	1.38	0.53"	3/8"

## PowerMax DriveN Pulleys

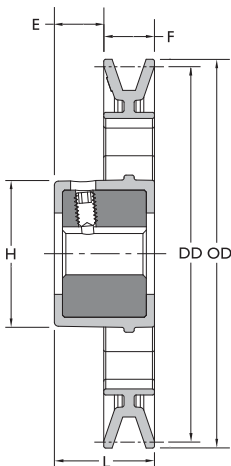

Type 1

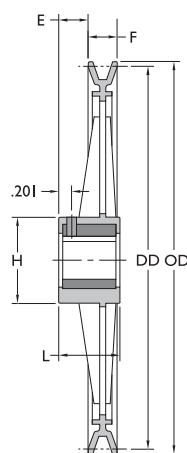

Type 2

Base Part Number	Dimensions (inches)						Belt Size	Diameter (inches)		Number Spokes	Spoke Style
	Type	E	F	H	L	Outside		Datum			
AFD44*	1	0.79	0.74	2.17	1.53	A/4L	4.25	4	-	-	
AFD49	1	0.79	0.74	2.17	1.53	A/4L	4.75	4.5	4	I-Beam	
AFD59	1	0.79	0.74	2.17	1.53	A/4L	5.75	5.5	4	I-Beam	
AFD74	1	0.79	0.74	2.17	1.53	A/4L	7.25	7	4	I-Beam	
AFD84	2	0.76	0.75	2.22	1.6	A/4L	8.25	8	6	Cross	
AFD94	2	0.76	0.75	2.22	1.6	A/4L	9.25	9	6	Cross	
AFD104	2	0.76	0.75	2.22	1.6	A/4L	10.25	10	6	Cross	
AFD112	2	0.76	0.75	2.22	1.6	A/4L	10.98	10.73	6	Cross	
AFD124	2	0.76	0.75	2.22	1.6	A/4L	12.25	12	6	I-Beam	

Shaft Size	Keyseat
5/8", 3/4"	3/16" x 3/32"
1"	1/4" x 1/8"

### Part Number Ordering Guide

Base Part Number	+	Shaft Size	=	Complete Part Number
AFD44		5/8"		AFD4458
AFD94		1"		AFD94100

Many idlers are, or can be, made into a driven pulley with a 5/8" or 3/4" bore. Please contact Fenner Drives for minimum order quantities, pricing, and availability.

- \* Minimums may apply
- † Insertion molded bearing
- ‡ Special 1" bore bearing with extended inner-race

# PowerMax™ Mounting Adapters and Pillow Block

THE POWERMAX ADVANTAGE

## Clevis Adapters

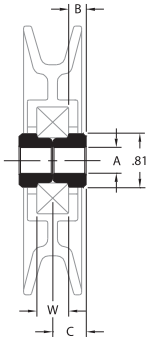

Part Number	Dimensions (inches)			
	A	B	W	C
CB0001	.385 / .395	0.26	0.472	0.5
CB0002	.385 / .395	0.51	0.472	0.75
CB0003	.385 / .395	0.76	0.472	1
CB0004	.510 / .520	0.26	0.472	0.5
CB0005	.510 / .520	0.51	0.472	0.75
CB0006	.510 / .520	0.76	0.472	1
CB0015	.314 / .324	0.08	0.472	0.32
CB0016	.385 / .395	0.17	0.472	0.41
CB0020*	.314 / .324	0.1	0.472	0.34
CB0023	.394 / .399	0.64	0.472	0.87
CB0036	.385 / .395	0.7	0.472	0.94
CB0058	.385 / .395	0.33	0.472	0.57
CB0100	.397 / .407	0.26	0.472	0.5

## Shoulder Adapters

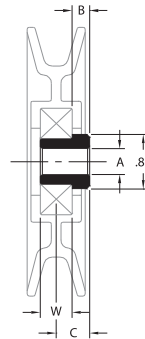

Part Number	Dimensions (inches)			
	A	B	W	C
SB0001	.385 / .395	0.26	0.472	0.5
SB0002	.385 / .395	0.51	0.472	0.75
SB0003	.385 / .395	0.76	0.472	1
SB0004	.510 / .520	0.26	0.472	0.5
SB0005	.510 / .520	0.51	0.472	0.75
SB0006	.510 / .520	0.76	0.472	1
SB0013	.385 / .395	0.15	0.472	0.38
SB0018	.385 / .395	0.4	0.472	0.64
SB0020	.385 / .395	0.59	0.472	0.83
SB0032	.385 / .395	0.56	0.472	0.8
SB0033	.385 / .395	0.95	0.472	1.19
SB0052	.385 / .395	0.71	0.472	0.95
SB0090	.255 / .265	0.31	0.472	0.55

## Bore Reducing Adapters

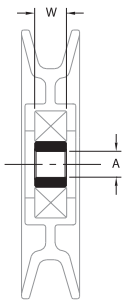

Part Number	Dimensions (inches)	
	A	W
RB0001	.385 / .395	0.472
RB0002	.510 / .520	0.472
RB0071	.474 / .486	0.472

\* Minimums may apply  
 † Insertion molded bearing  
 ‡ Special 1" bore bearing with extended inner-race

## PowerMax™ Pillow Blocks

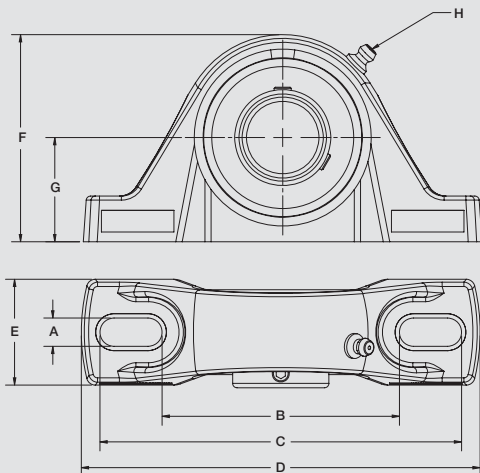

Part Number	Dimensions (inches)								Zerk	Bearing Type	Bore Size
	A	B	C	D	E	F	G	H			
PB1000	0.39	3.3	4.9	5.7	1.6	2.8	1.45	No	SB205-16	1"	
PB1032	0.51	4.38**	N/A	5.7	1.6	2.8	1.45	No	SB205-16	1"	
PB2050	0.39	3.3	4.9	5.5	1.5	2.9	1.44	Yes	SB205-16	1"	

NOTE: Also available in the following bore sizes 7/8", 15/16" and 25mm as a non catalog item.  
 Subject to minimum order quantities.

\*\* Dimension (B) is the hole center distance, (A) is the hole diameter

Basic Dynamic Load Rating: 3145 lbf  
 Static Load Rating: 1750 lbf



www.fennerdrives.com

US and Canada • 1 800 243 3374

Latin America • 1 717 665 2421

Europe, Asia, Australia and Africa • +44 0 870 757 7007



Information subject to change without prior notification. Visit [www.fennerdrives.com/catalogs](http://www.fennerdrives.com/catalogs) for the most current information.